

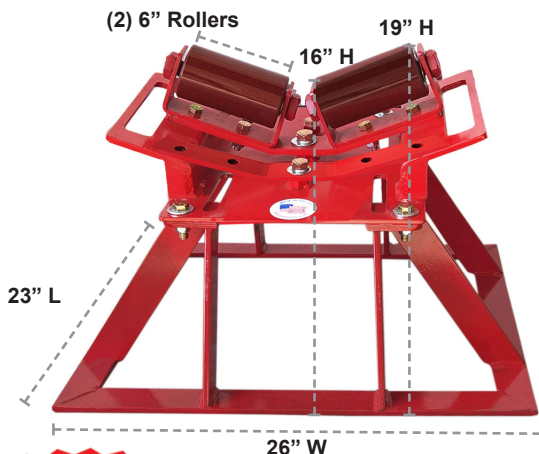

# Pipe & Industrial Tools™

## SPEC SHEET 2" - 24" PIPE LAUNCHER PN 2115 SERIES

### PN 2115



**CONVERTIBLE!**  
Remove base for  
beam clamp roller.

### PN 2115HD

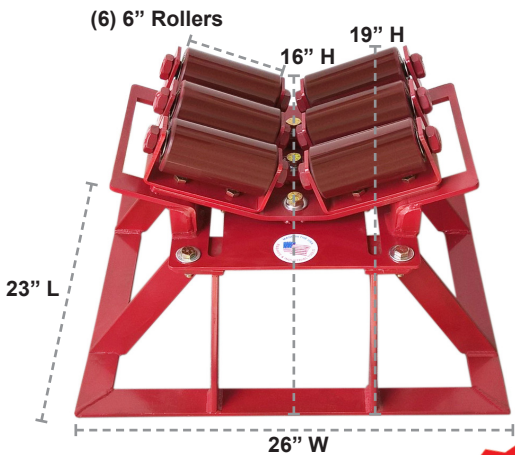

**EXPANDABLE!**  
Add rollers to  
increase capacity.

### SPECIFICATIONS

- Pipe capacity: 2" - 24"
- Weight capacity: PN 2115 - 2,500 lbs.  
PN 2115HD - 7,500 lbs.
- Shipping weight: PN 2115 - 89 lbs.  
PN 2115 HD - 125 lbs.
- Dimensions: PN 2115 - 23" L x 26" W x 16" - 19" H  
PN 2115HD - 23" L x 26" W x 16" - 19" H
- Urethane over steel wheels with sealed bearings.
- 6" wheels.
- 2115: 2 wheels, 2,500 lbs. capacity  
2115HD: 6 wheels, 7,500 lbs. capacity
- All wheels and housings are replaceable.
- Carry handles.
- Powder coated safety red.
- Stackable nesting design.



PN	Description	Pipe Capacity	Weight Capacity	Shipping Weight	Dimensions (inches) L x W x H1-H2
2115	Beam Clamp Roller (Two Rollers)	2" - 24"	2,500 lbs.	89 lbs.	23" x 26" x 16" - 19"
2115HD	Beam Clamp Roller HD (Six Rollers)	2" - 24"	7,500 lbs.	126 lbs.	23" x 26" x 16" - 19"